

mimSAFE

newera.mimsafe.com

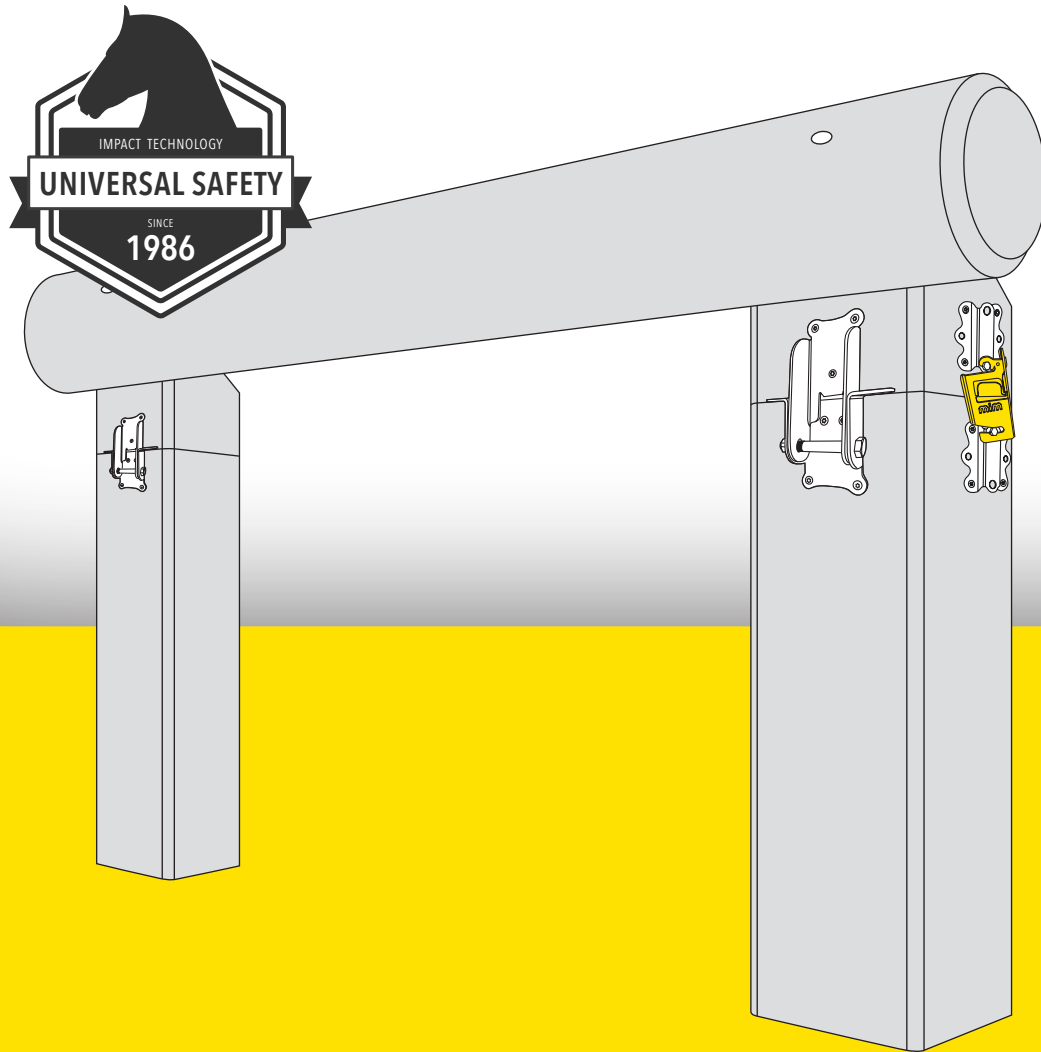

ASSEMBLY INSTRUCTIONS
**POST & RAIL
SKINNY/ANGLED KIT**

NEWERA USIT SYSTEM

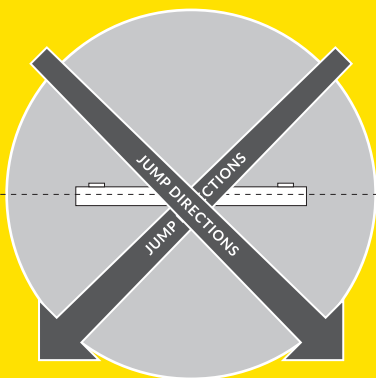



APPROVED

INFORMATION ABOUT THE POST & RAIL SKINNY/ANGLED KIT

The Post & Rail Skinny/Angled Kit has been designed and developed specifically to greatly reduce the risk of rotational falls. The most important element of this kit is that it will not break the fence or risk injury

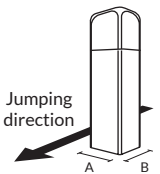
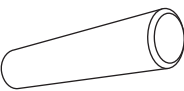
to the horse if hit vertically. The rail is only released when impacted horizontally by the horse. The risk of a resulting rotational fall is thus reduced.

RECOMMENDED FENCE DIMENSIONS	
<p>POST</p> 	<p>RAIL</p> 
A: MIN-MAX SIZE	
6 - 8	inch
150 - 200	mm
B: MINIMUM-SIZE	
6	inch
150	mm
<p>Check</p> 	
MIN-MAX WEIGHT	
132 - 198	lb
60 - 90	kg
MIN-MAX DIAMETER	
8 - 12	inch
200 - 300	mm
MAXIMUM LENGTH	
12	ft
360	cm



It is essential to follow the recommended dimensions on the fence for the correct function. If the recommended procedure is not correctly followed it may cause the failure of the device.

For your own safety and that of others please note the following step by step advice for correct preparation and installation. It is important that you follow your own health and safety requirements when constructing this kit.

Ensure that you have all parts of the Post & Rail Skinny/Angled Kit.

Be aware of the risk of injury when handling heavy rails, poles and the tools for mounting.

WARNING!

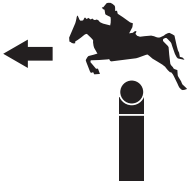

Jumping direction

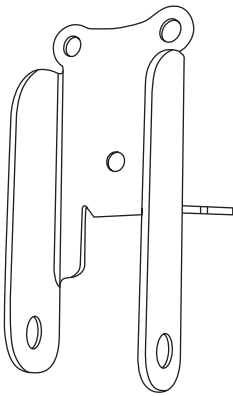
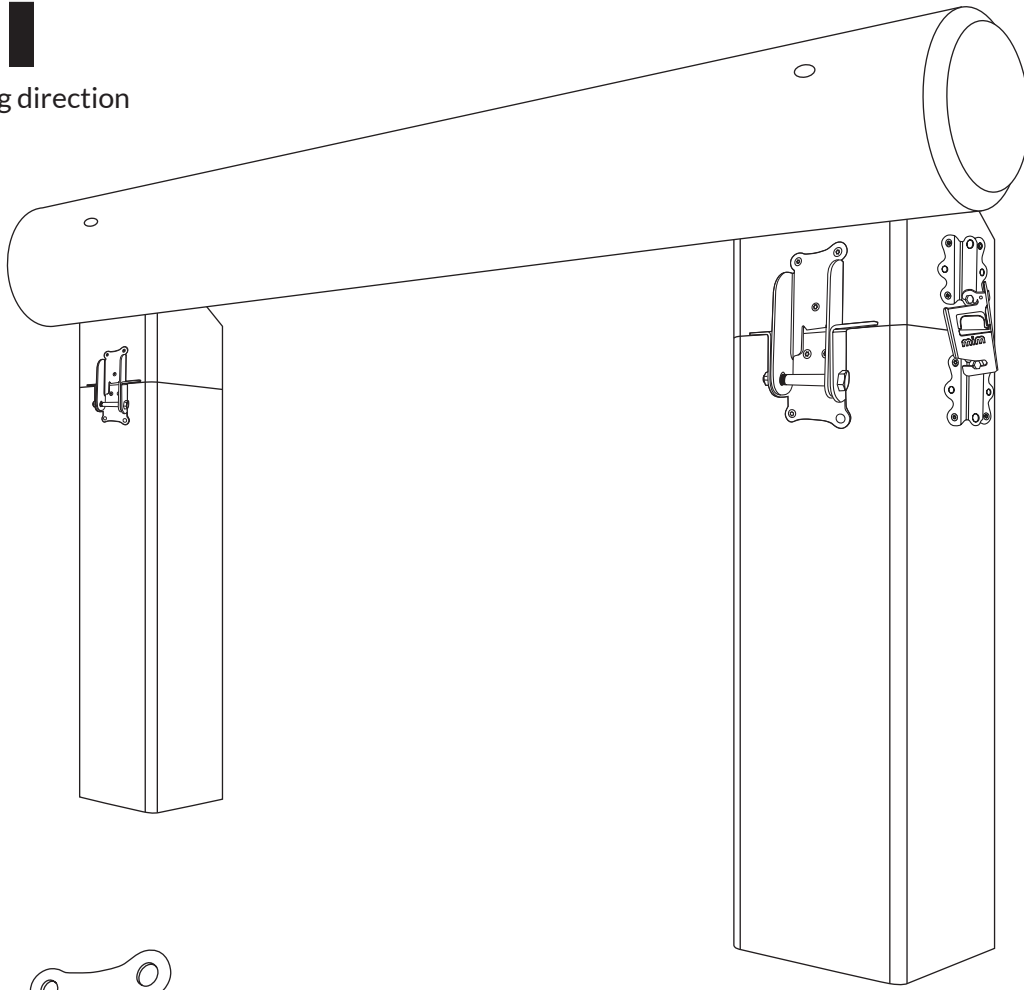

A F76D
Part no 2x

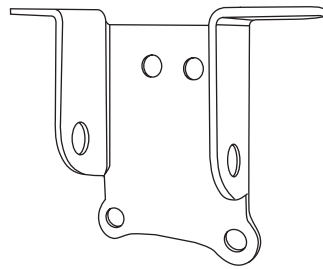

B F76C
Part no 2x

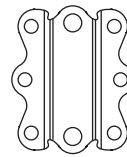

C F70A
Part no 4x

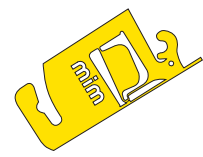



D F18F
Part no 6x

M-SM12x90 2X	M-BR12x22x2s 2X	M-MM12Ny 2X	M-TS10X90 4X	POST TOP SECTION 2X	POST BOTTOM SECTION 2X	RAIL 1X
				not included	not included	not included

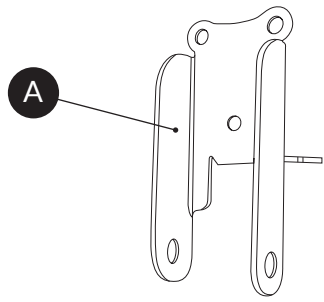
STEP
1



2X

M-SM12x120 1X	M-BR12x22x2s 1X	M-MM12Ny 1X
		

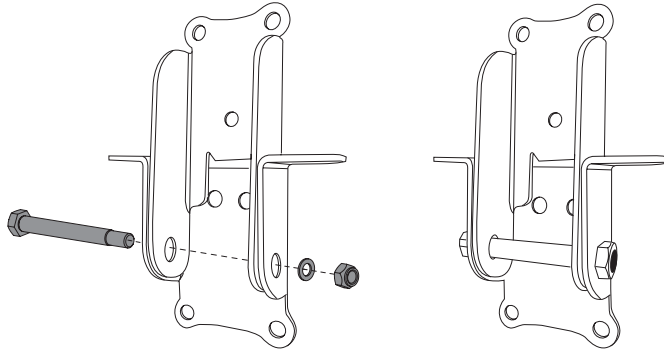
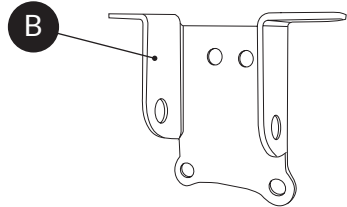

STEP
2

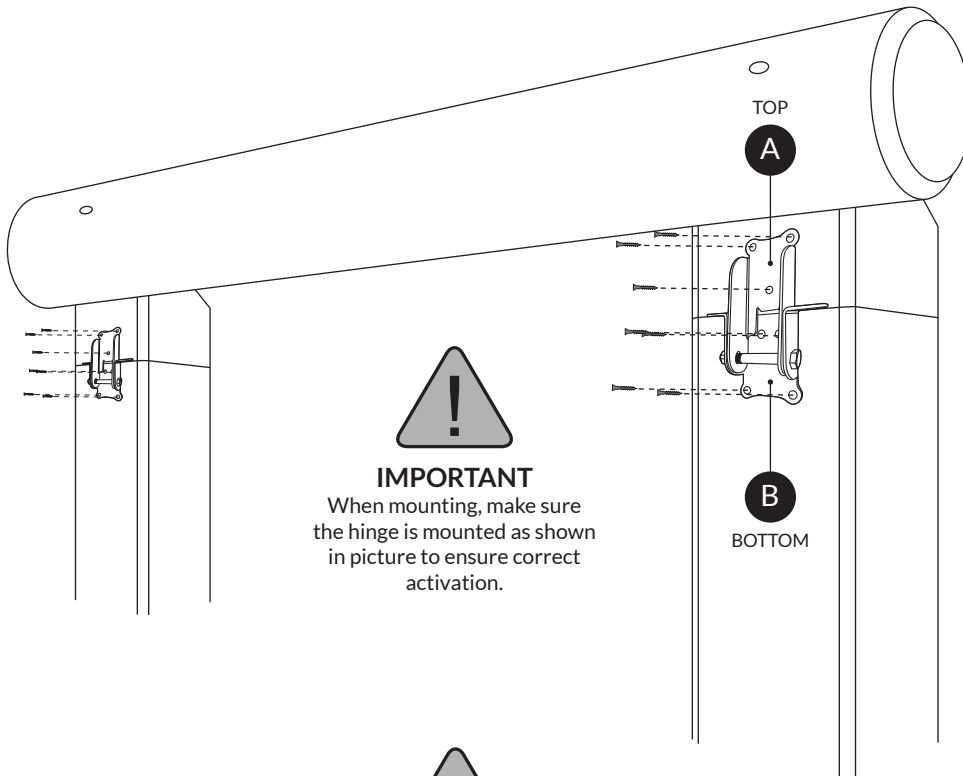

IMPORTANT

When mounting, make sure the hinge is mounted as shown in picture to ensure correct activation.



IMPORTANT

Make sure you follow the cutting measurements for correct fence release/function

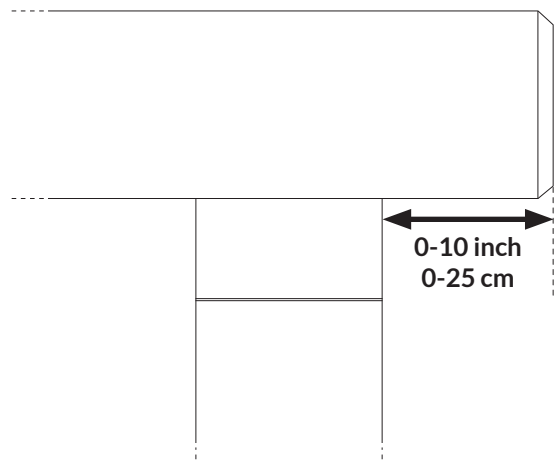
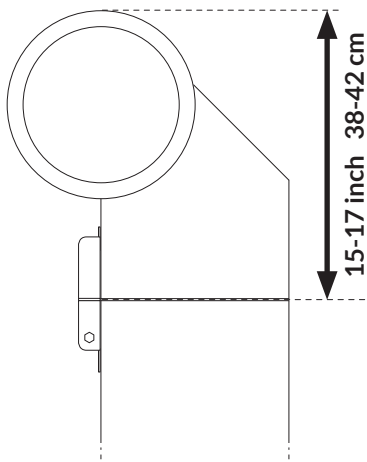

STEP
3

CORRECT alignment of the clip

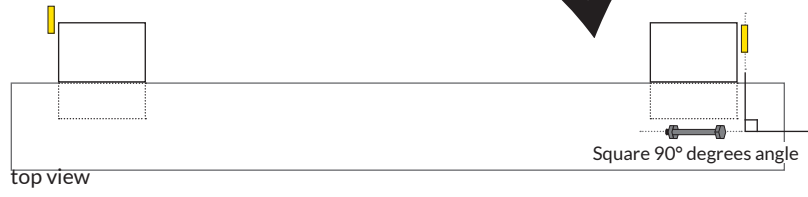

WRONG alignment of the clip

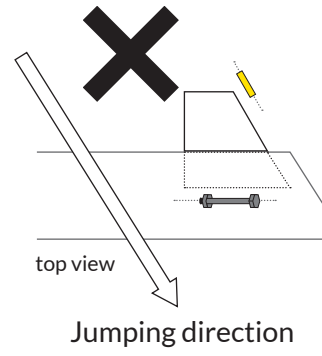

STEP
4



IMPORTANT
USE M12 or UNC 1/2"
to make sure the horizontal rail
is rigid fixed to the posts.

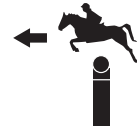
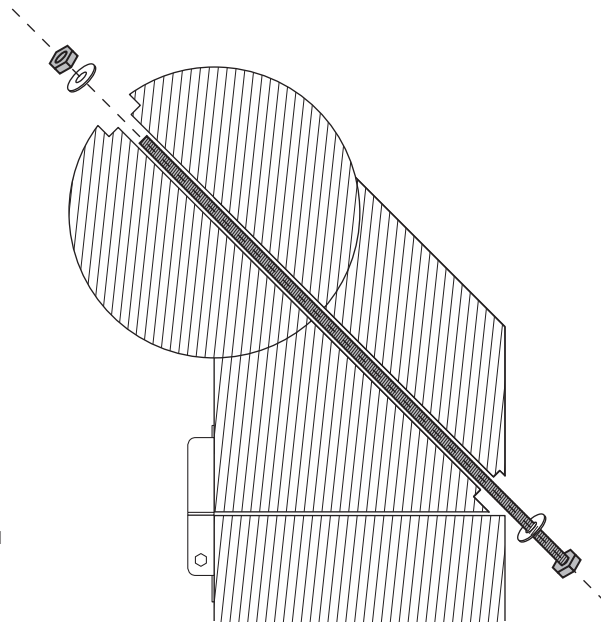

Jumping direction

2X

STEP
5

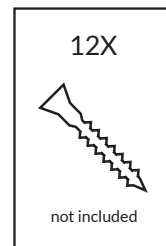
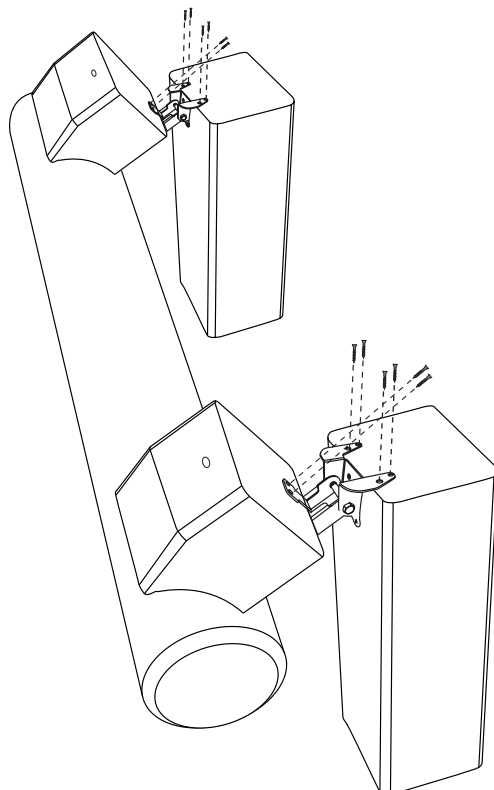



IMPORTANT

Make sure you follow the mounting measurements for correct fence release/function

There is no difference in the releasing force depending on the clip's orientation, vertical or horizontal, as long as the distance from the hinge bolt to the clip follows the instructions.

2X

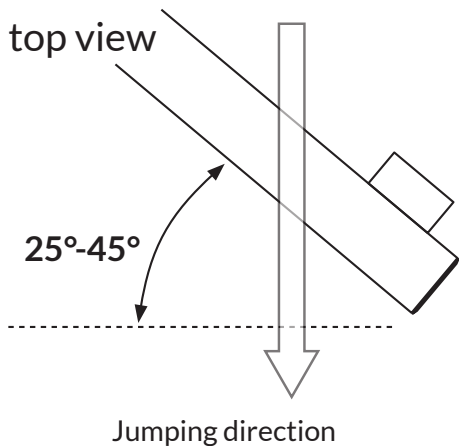
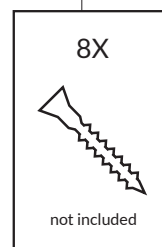
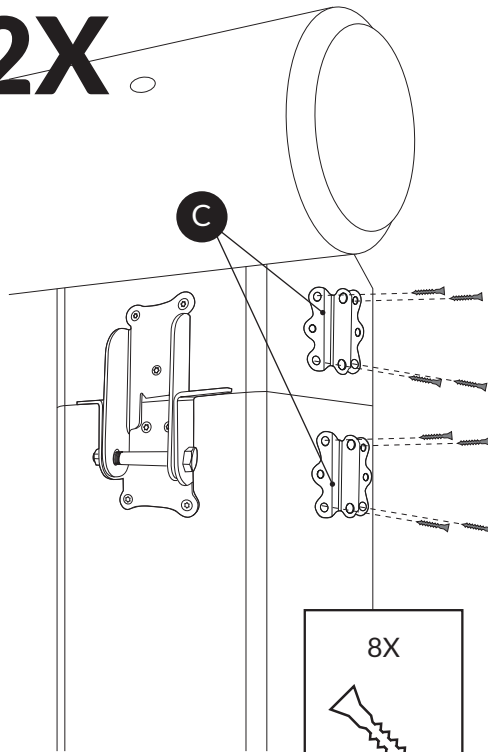

A

8" ± 0.2"
20 ± 0,5 cm

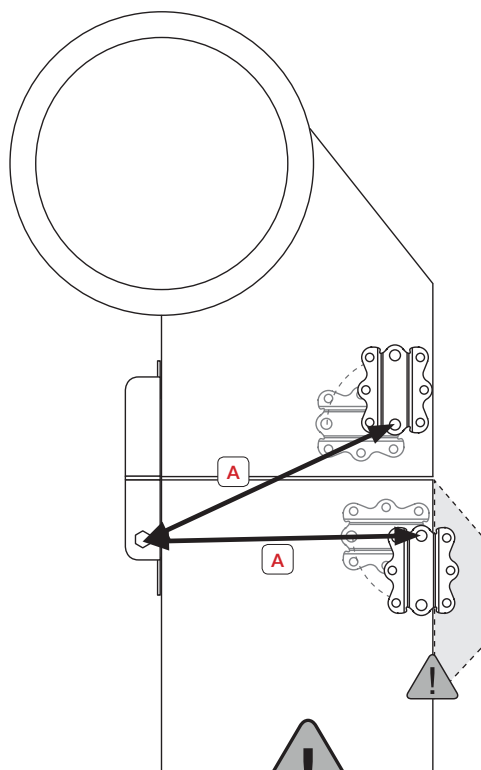

IMPORTANT

Add on material for the bracket C if post is too thin

STEP
7

2X

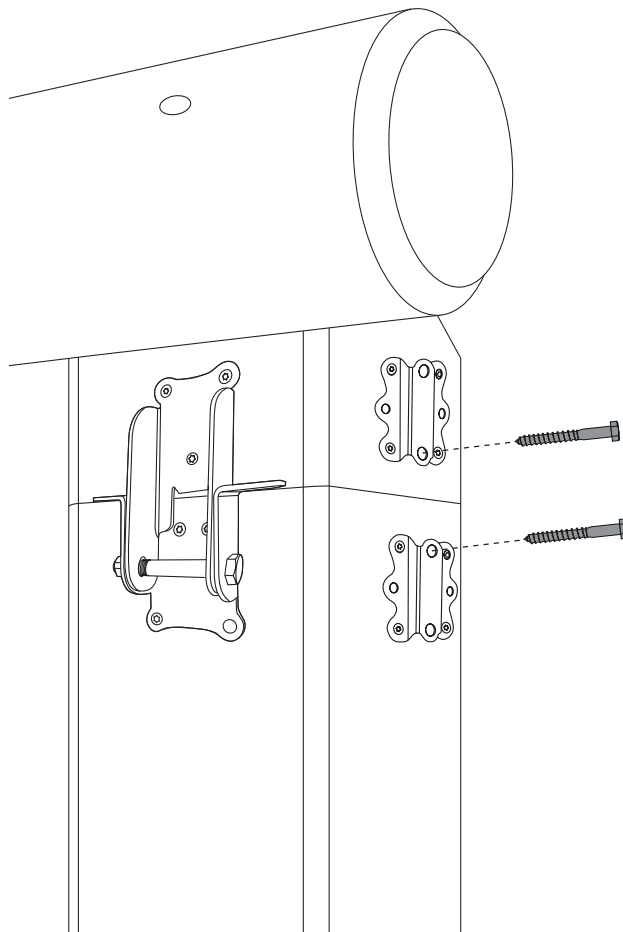
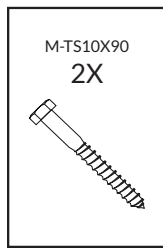

STEP
8

2X

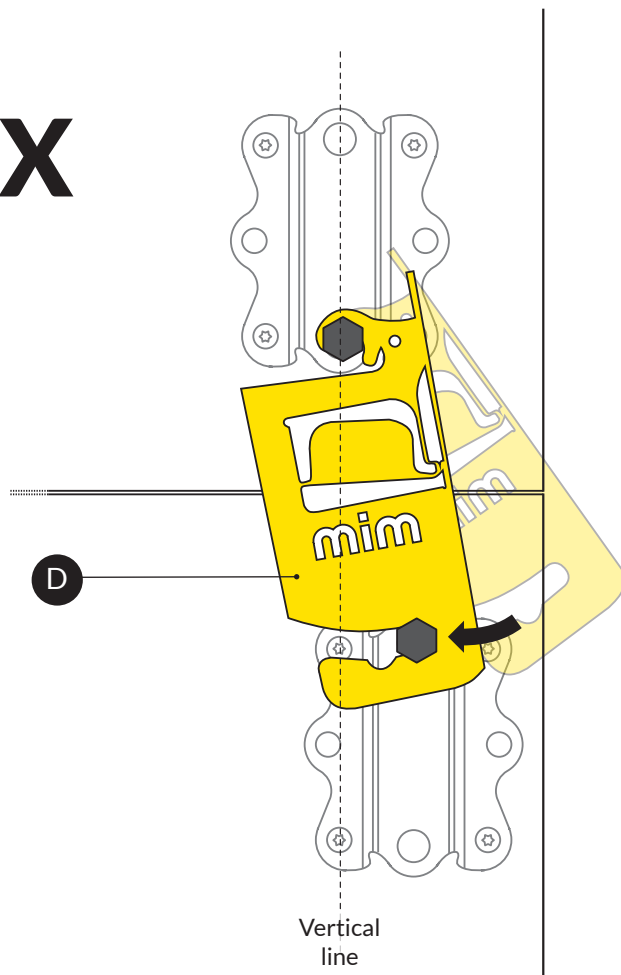

IMPORTANT



Distance between brackets
should be adjusted to avoid
clip D rattling.



IMPORTANT

When top section is released the gap between top section and bottom section should be **maximum 50 mm**.

If gap is wider, then place object to shrink/reduce the gap.

When top section is released the distance between top section and ground should be **minimum 200 mm**.

If distance between ground and top section is less, then place an object which will prevent the top section falling into the **SAFE AREA**

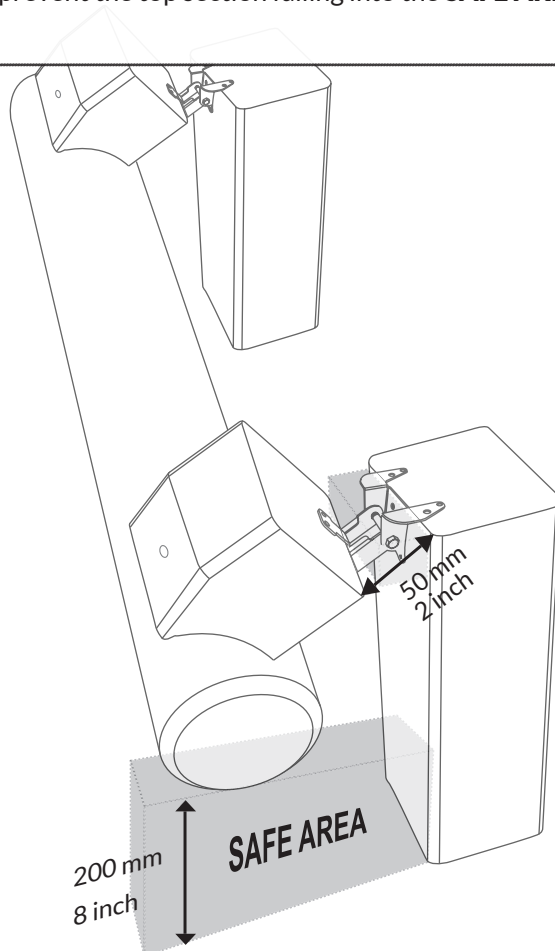

The advantages of the Post & Rail Skinny/Angled Kit

1. It has been produced with safety being the first and foremost important factor.
2. Reduces the possibility of rotational falls.
3. FEI approved number FEI01SWE.
4. Controlled movement of fence during release.
5. Reconstruction time is less than 30 seconds.
6. The parts are made of powder coated steel and can be left outside, no maintenance is required.
7. The very highest quality of product from Sweden ISO 9001.

The Mim clip (F18F) breaks on impact, which clearly indicates when replacement is needed. The top section is connected to the post with a hinge that makes the fence easy to reconstruct. This saves time, guarantees fair and correct judging for riders and contributes to the overall safety of the sport.